

SET-UP:
GRAPHIC COMES ATTACHED

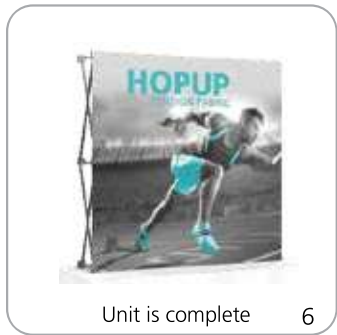

TO ATTACH END CAPS

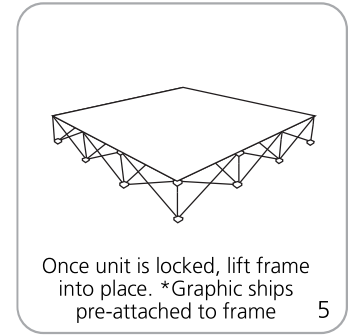
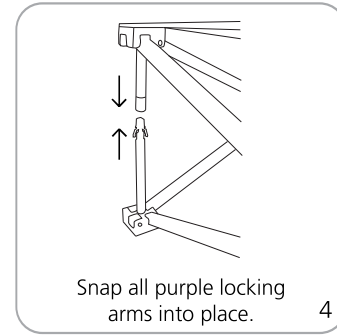
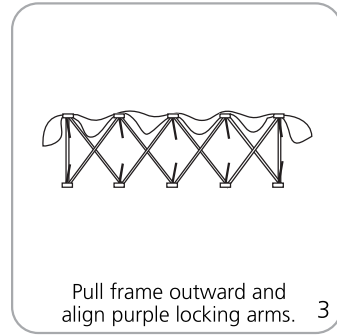
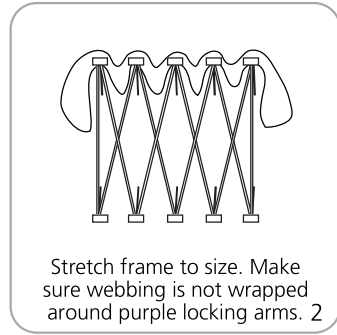
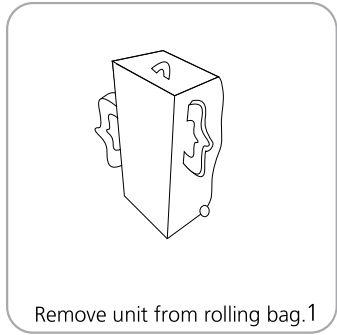
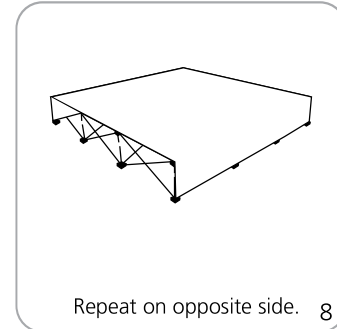
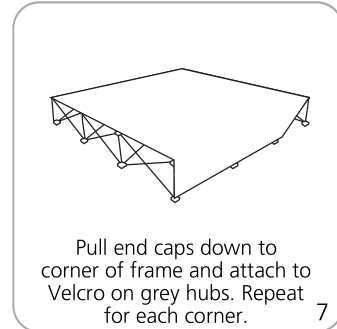

ATTACH STABILIZER FEET TO FRAMES 3 QUADS HIGH

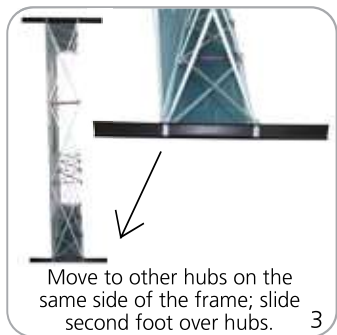
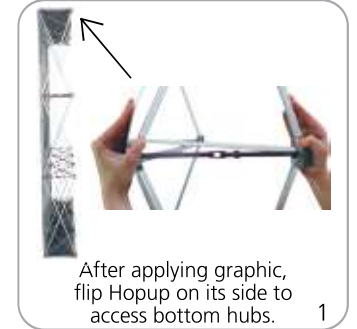

TO ATTACH LIGHTS

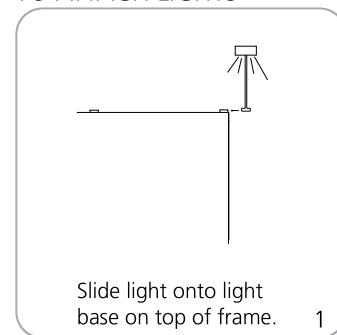

TO COLLAPSE

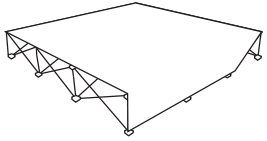

To collapse unit, first remove end cap graphics on both sides and fold onto top of frame. 1

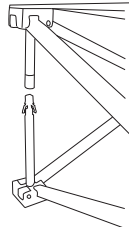

Unlock all purple locking arms. *Note: for 5x3 size, release locking arms from outside perimeter frame to the inside. 2

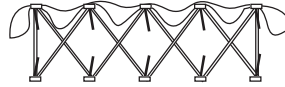

Once all arms are unlocked, slowly push frame inward to collapse. 3

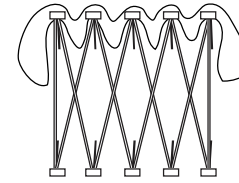

Continue to collapse frame, making sure graphic and webbing do not entangle with purple locking arms. 4

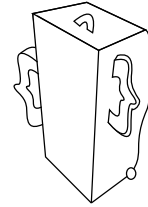

Store unit into rolling bag. Be sure bag straps do not wrap around purple locking arms. 5

to ensure quality, please note:



If the webbing is wrapped around the purple locking arm, the arm can snap off when opening the unit.



When setting up, ensure that the arms are aligned. If not, the arms will snap when pressure is applied.



When packing unit in the bag, ensure that the strap is not partially wrapped around an arm. If it is, the arm will snap when pulled out of the bag.



Do not use the purple locking arm to lift unit. ALWAYS lift by the frame.

Curved Hopup

The curved HopUp gives your tension fabric backwall visual interest and dimension.

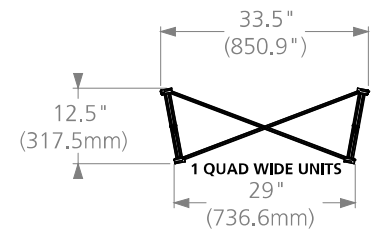
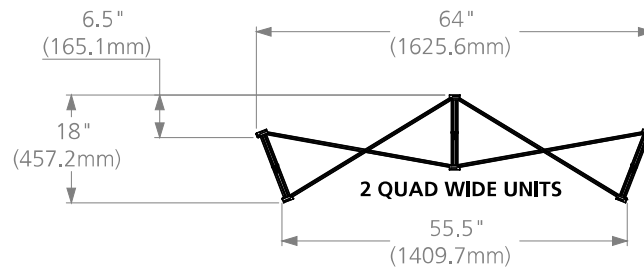
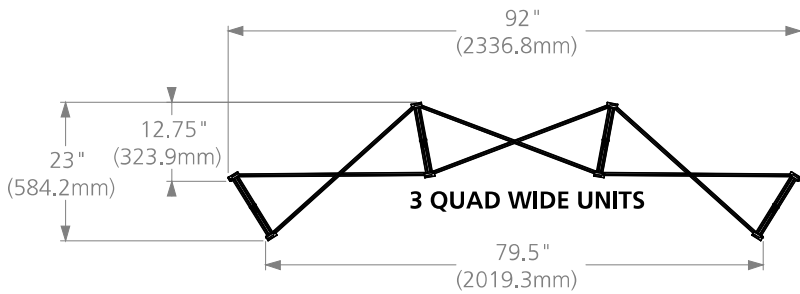
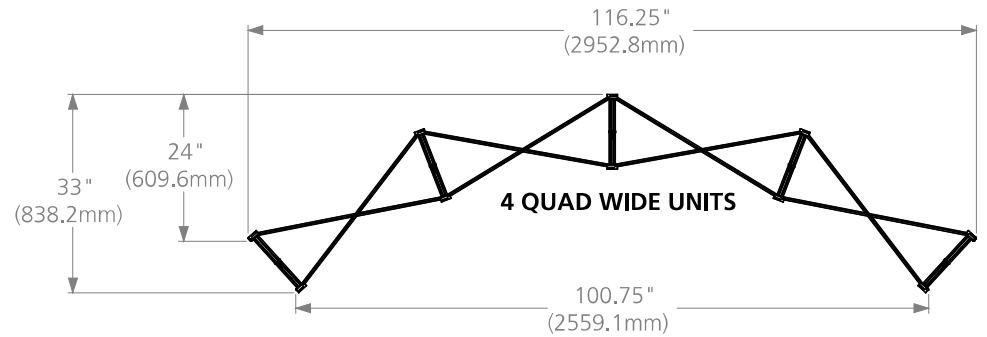
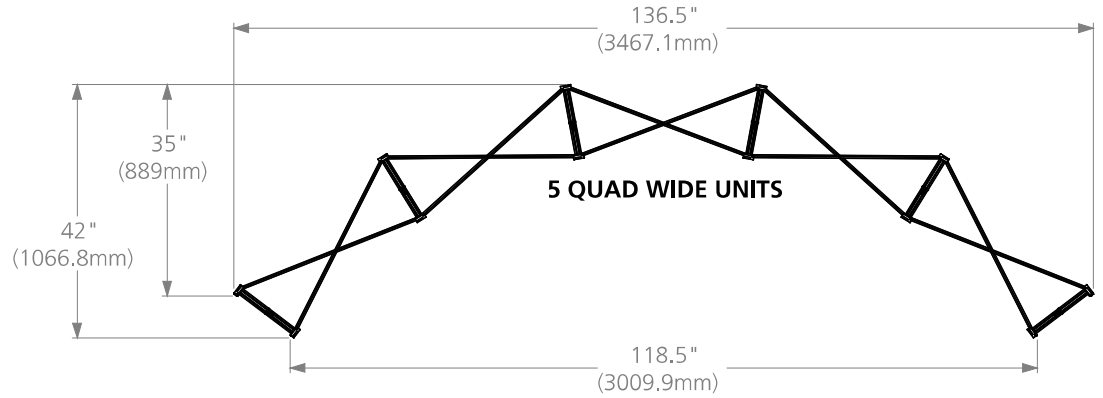

Straight Hopup

Straight Hopup frame footprints fit in a 10' x 10' space, with the exception of 5 quad wide units which fit in a 10' x 13' space. Stabilizer feet present on all straight frames 3 quads high.

